

HAMMER STRENGTH EQUIPMENT

BWAB – Body Weight AB Board

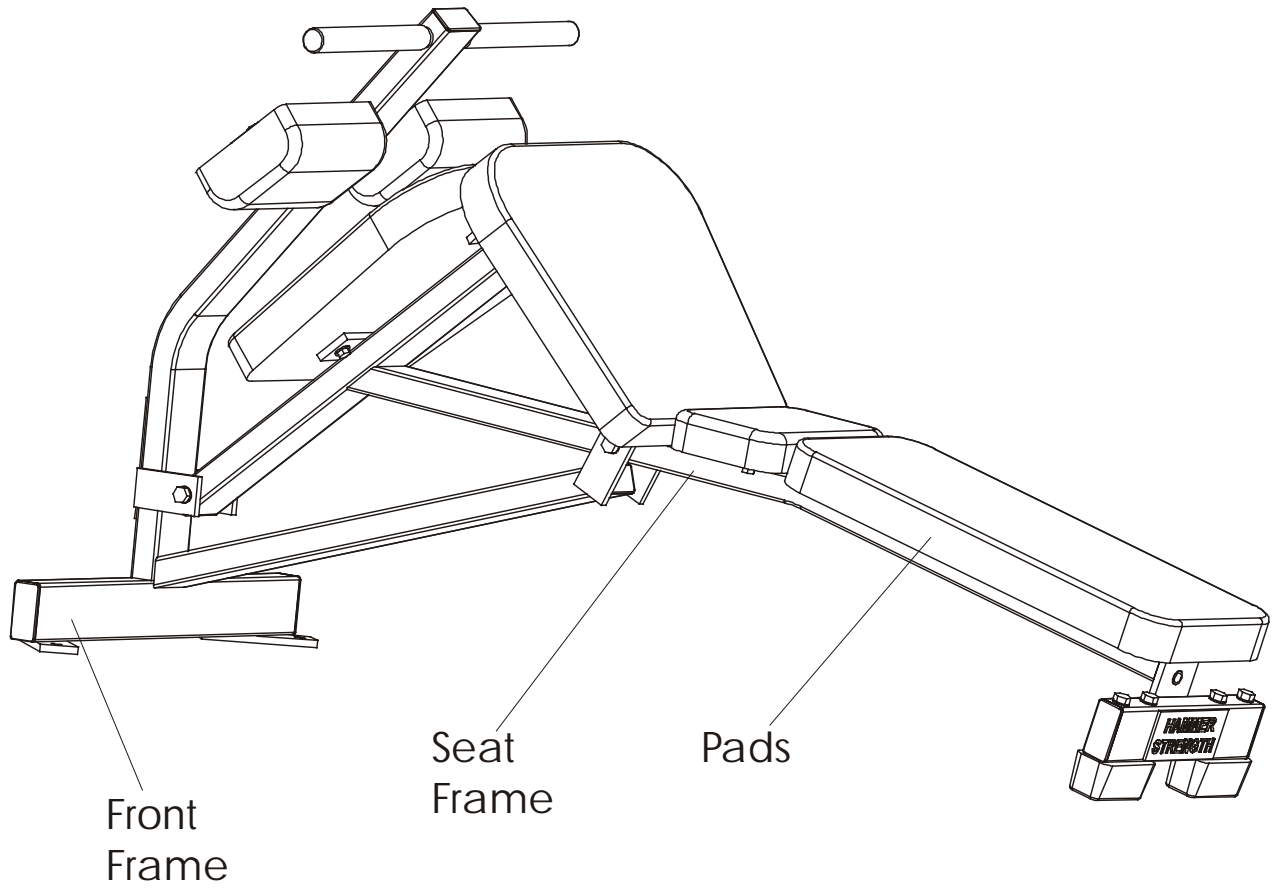

HAMMER STRENGTH EQUIPMENT

BWAB – Exploded Assembly

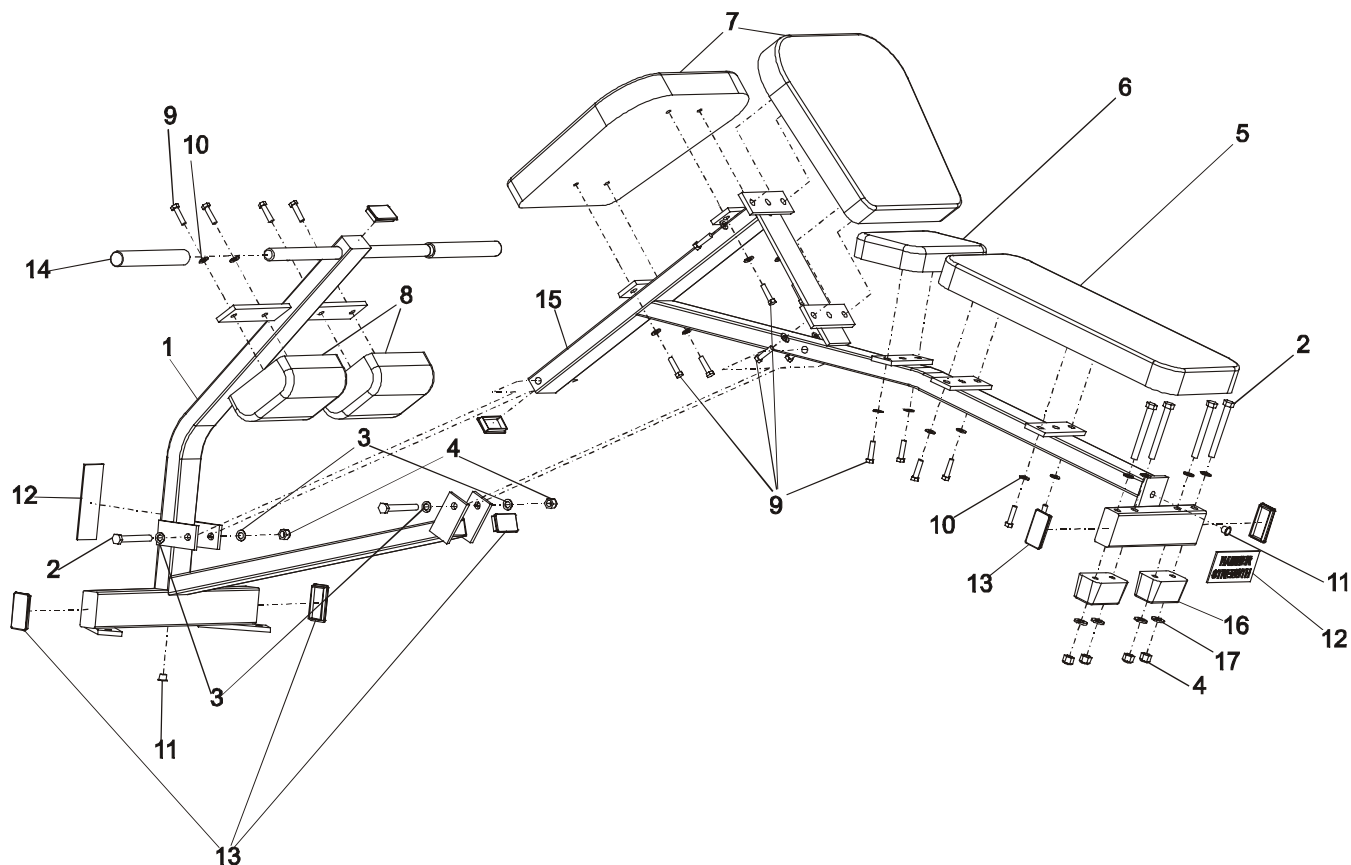

ITEM NO.	QTY.	PART NO.	DESCRIPTION
1	1	BWAB-SF-0	Front Frame
2	6	HHB.5X4.5	1/2 X 4 1/2 Bolt
3	8	WASH.5STAR	1/2" Internal Lock Washer
4	6	NUT.5LOCK	1/2" Thick Lock Nut
5	1	U24-10	Standard 24" Pad
6	1	U10-4.5	Pad, 10-4.5
7	2	U16-11	Standard 16" Pad
8	2	U8-4.5	Standard 8" Pad
9	18	HHB.375X1.5	3/8 X 1 1/2 Bolt
10	18	WASH.375SAE	3/8" SAE Flat Washer
11	2	H-HPLUG	Hole Plug
12	2	H-NAMEPLATE	Name Plate
13	7	H-PEND3	1 1/2 X 3 End Cap
14	2	H-GRIP(BWAB-A00)	HandGrip
15	1	BWAB-ST-0	Seat Frame
16	2	H-BUMP-MED	MM2 Medium
17	4	WASH.5SAE	1/2" SAE Flat Washer