

**HAMMER STRENGTH EQUIPMENT**  
**FWDB-A01 Free Weight Decline Bench Assembly**

---

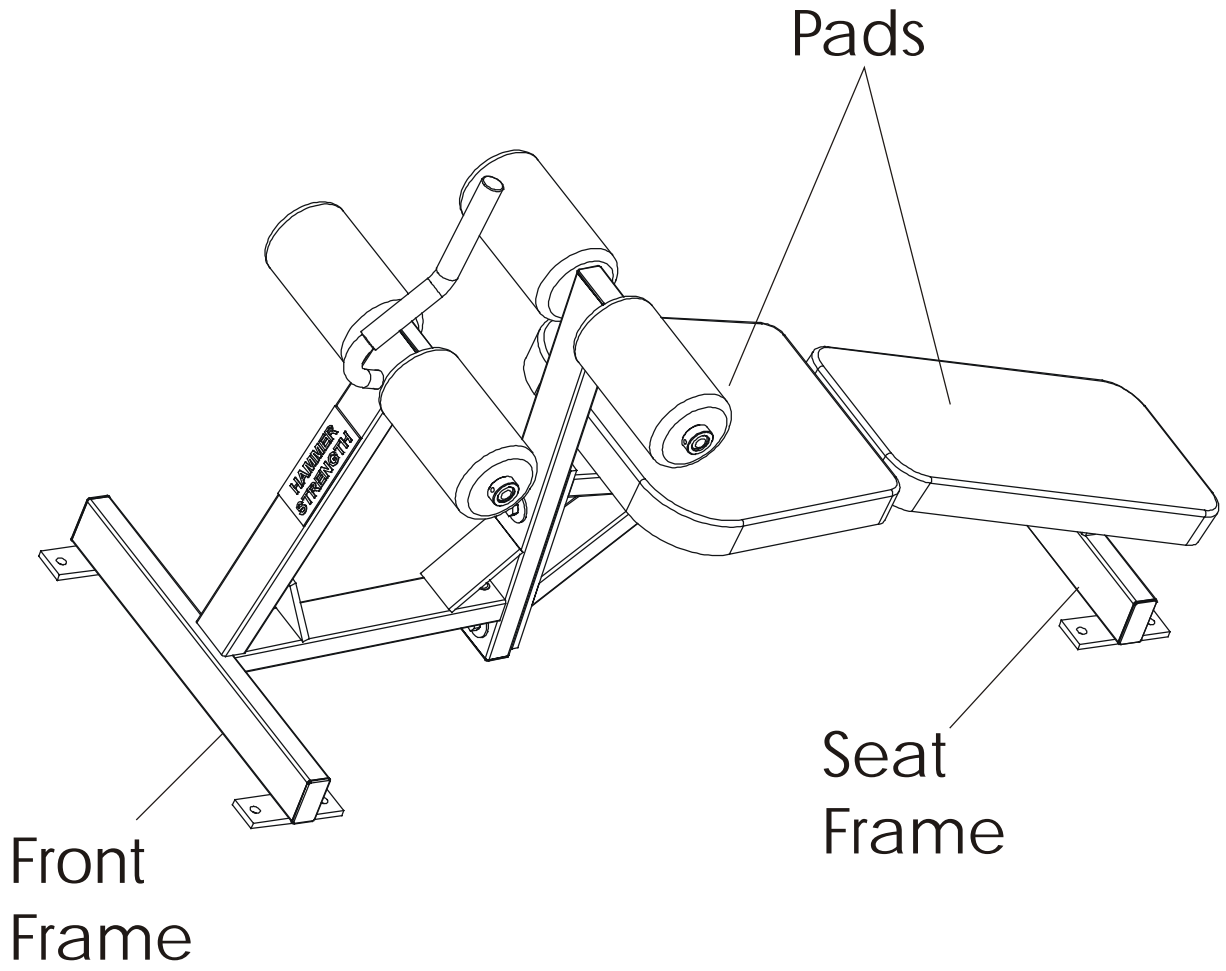

# HAMMER STRENGTH EQUIPMENT

## FWDB- A01 Exploded Assembly

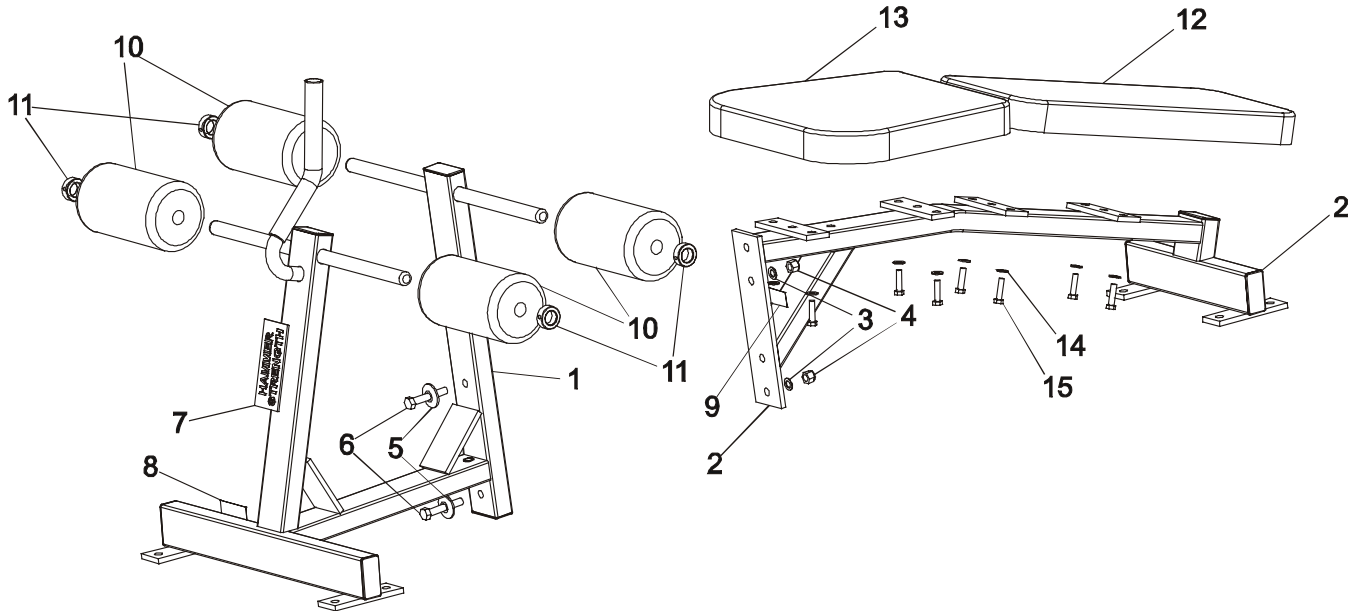

ITEM NO	QTY	PART NO.	DESCRIPTION
1	1	FWDB-CSF-1	Front Frame Assembly
2	1	FWDB-CST-0	Seat Pad Frame Assembly
3	2	WASH.5STAR	1/2" Internal Lock Washer
4	2	NUT.5LOCK	1/2" Thick Lock Nut
5	2	H-BACK-WASH	Backing Washer
6	2	HHB.5X3	1/2 X 3 Bolt
7	1	H-NAMEPLATE	Name Plate
8	1	PATENT	Patent Decal
9	1	SERIAL NUMBER	Serial Number
10	4	URP-1	Roller Pad
11	4	H-LCOLLAR1	3/4" Lock Collar
12	1	U24-10	Standard 24" Pad
13	1	U16-11	Standard 16" Pad
14	8	WASH.375SAE	3/8" SAE Flat Washer
15	8	HHB.375X1.5	3/8 X 1 1/2 Bolt

# HAMMER STRENGTH EQUIPMENT

## FWDB- A01 Front Frame

---

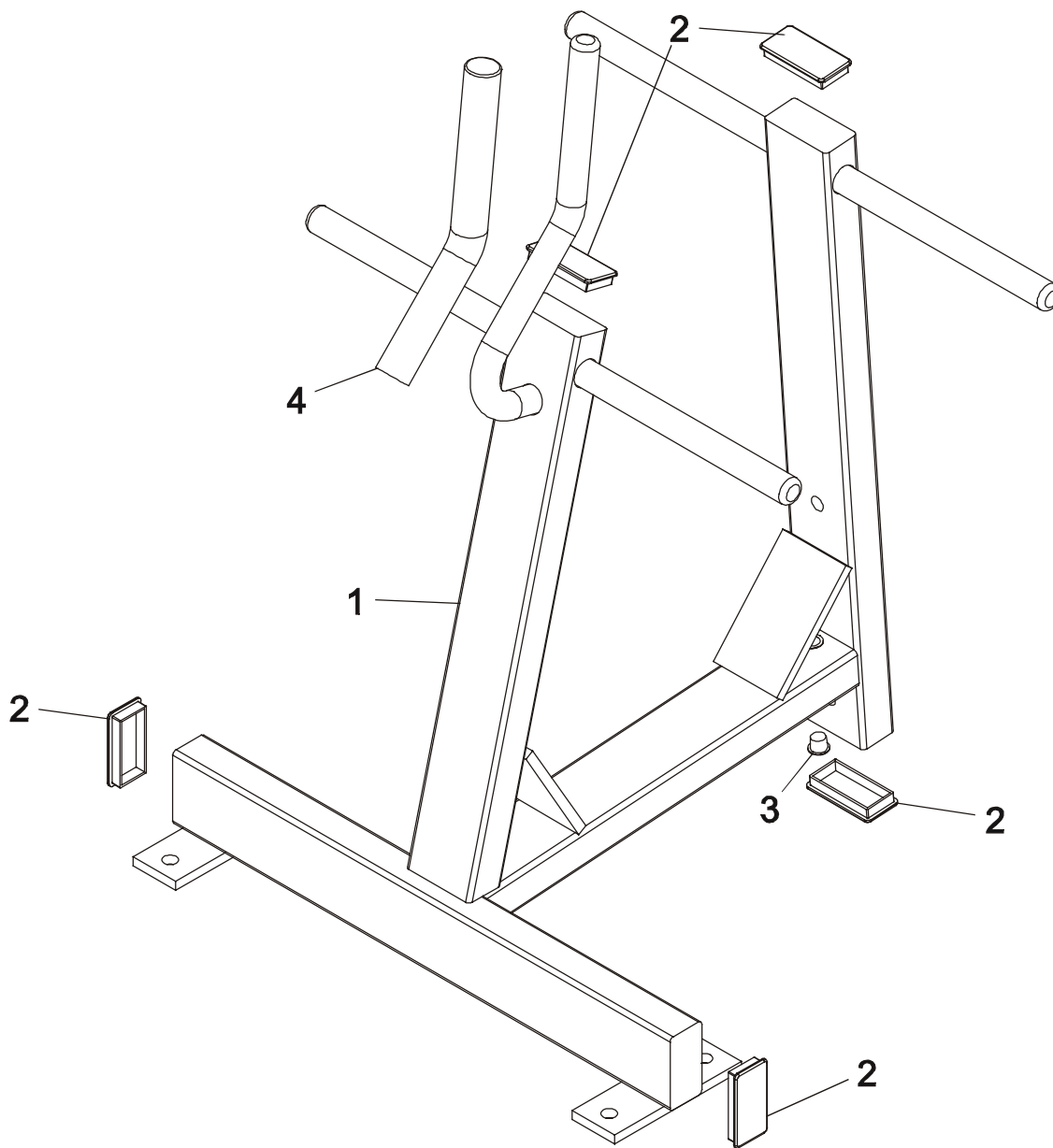

ITEM NO	QTY.	PART NO.	DESCRIPTION
1	1	FWDB-SF-1	Front Frame
2	5	H-PEND3	1 1/2 X 3 End Cap
3	3	H-HPLUG	Hole Plug
4	1	H-GRIP(BWBD-A00)	HandGrip

# HAMMER STRENGTH EQUIPMENT

## FWDB- A01 Seat Frame

---

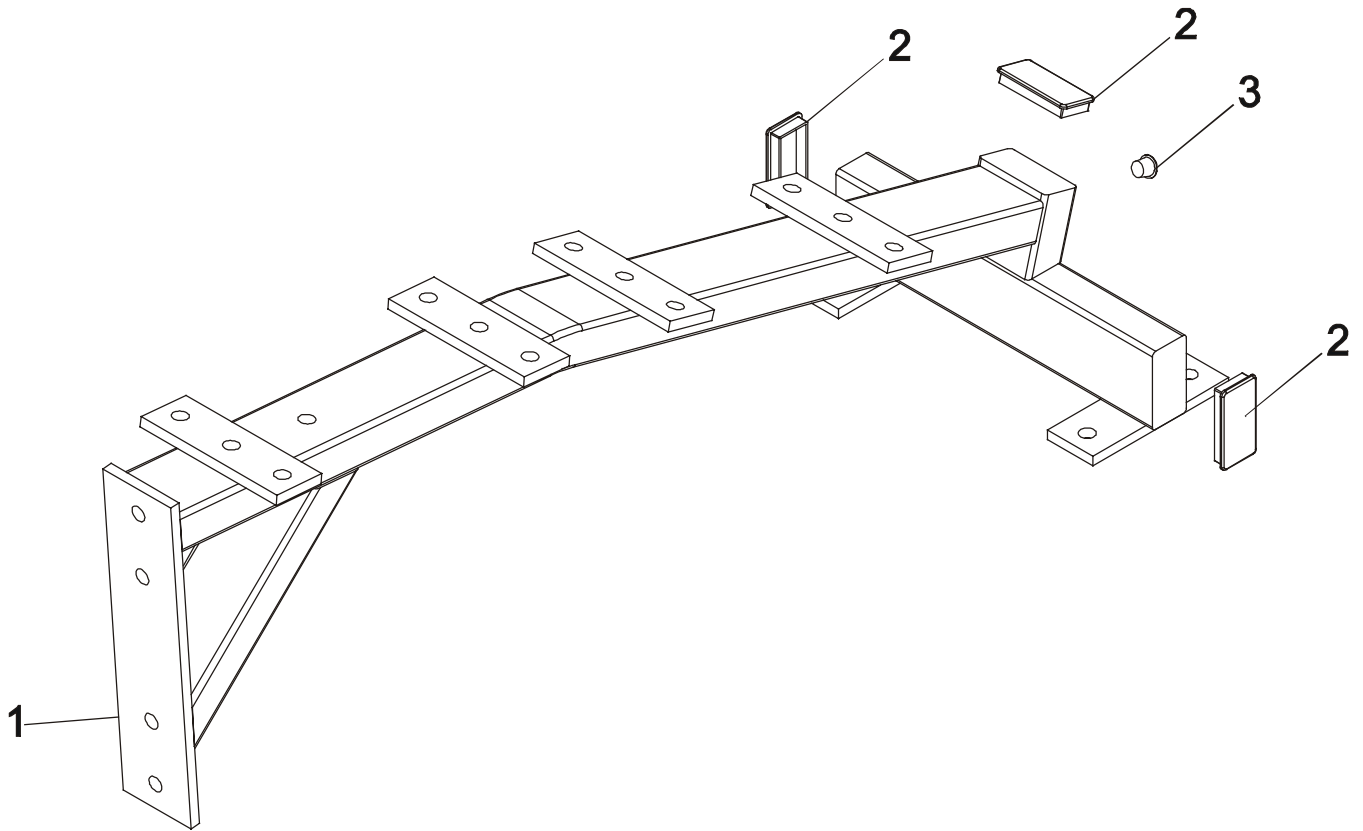

ITEM NO	QTY.	PART NO.	DESCRIPTION
1	1	FWDB-ST-0	Seat Frame
2	3	H-PEND3	1 1/2 X 3 End Cap
3	1	H-HPLUG	Hole Plug